

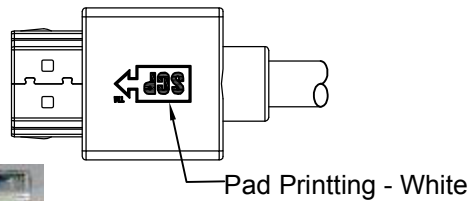

THESE DRAWINGS AND SPECIFICATIONS ARE THE PROPERTY OF **STRUCTURED CABLE PRODUCTS** AND SHALL NOT BE REPRODUCED COPIED OR USED IN ANY MANNER WITHOUT THE PRIOR WRITTEN CONSENT OF **STRUCTURED CABLE PRODUCTS**

REV.	REVISED DESCRIPTION	DATE	CHECKED
A1	FIRST RELEASE	2016.05.17	
A2	Change a new model of forming die and plug specifications	2016.06.22	

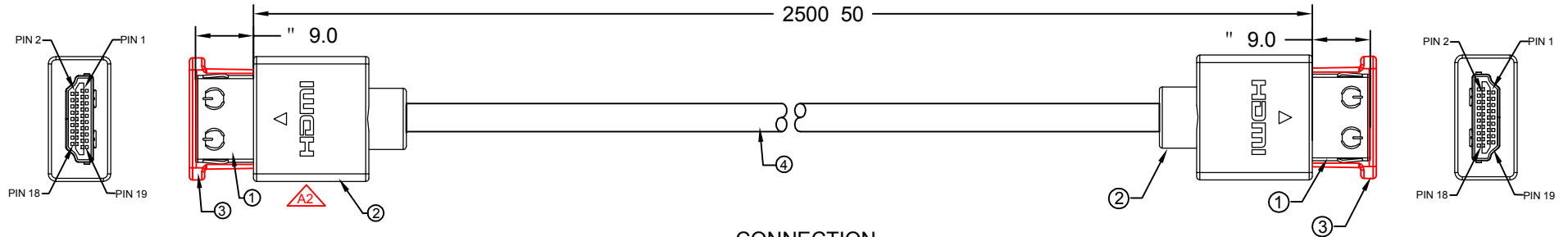

Packing: 1PC / Blister

CONNECTION

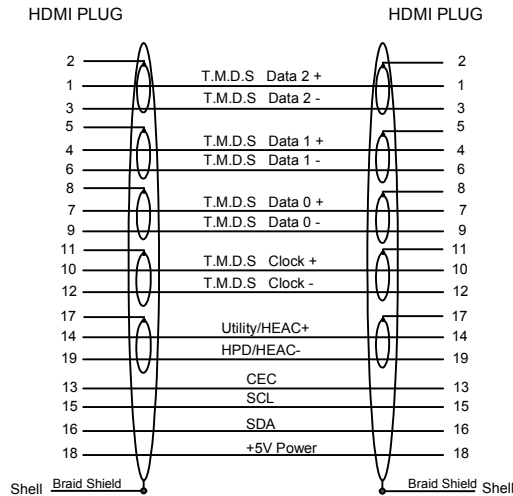

- ELECTRIC TESTING:
 1. 100% OPEN & SHORT TESTING
 2. INSULATION RESISTANCE: 20 M
 3. CONDUCTOR RESISTANCE: ! 3
 4. VOLTAGE: 300V DC/0.1S

www.scpca5e.com

ITEM	SPECIFICATION
4	Cable Spec: {[(1/0.203Bc+HDPE)*5P+1/0.203Tc+AL/Mylar]*5+ (1/0.203Bc+HDPE)*4C+Cotton+AL/Mylar+16/11/0.08Tc 85%}*1C OD:5.0 0.15mm Jacket=Black PVC with White Text:PREMIUM HIGH SPEED HDMI R(logo) CABLE WITH ETHERNET UL(Logo) AWM 20276 VW-1 80°C 30V E81280-D CHING TAI
3	Plastic Cap-Transparent(2312110024)
2	PVC - Black 60P (31401012060 YT-3497 / YT-3498)
1	HDMI Plug - Gold Plated (3033700A9G)

TOLERANCES UNLESS OTHERWISE STATED

⌀	≡	X.	= ± 1
		.X	= ± 0.2
		.XX	= ± 0.1

Structured Cable Products™
Quality Installations Deserve Quality Products

ERP NO.:		Sample No.	
DOC No.:		REVISION	A2
CUSTOMER:	SCP	UNIT	mm
CUSTOMER P/N:	991UHD-2.5M	SCALE	NO
DESCRIPTION	Premium 2.0 HDMI A/P - HDMI A/P 32#	PAGE NO	1/1
		DATE	2016.06.22
APPROVAL	CHECKED	DRAWN	CJJ