

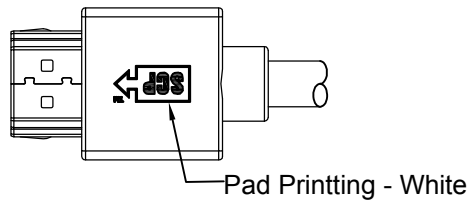

THESE DRAWINGS AND SPECIFICATIONS ARE THE PROPERTY OF **STRUCTURED CABLE PRODUCTS** AND SHALL NOT BE REPRODUCED COPIED OR USED IN ANY MANNER WITHOUT THE PRIOR WRITTEN CONSENT OF **STRUCTURED CABLE PRODUCTS**

REV.	REVISED DESCRIPTION	DATE	CHECKED
A1	FIRST RELEASE	2016.05.17	
A2	Change a new model of forming die and plug specifications	2016.06.22	

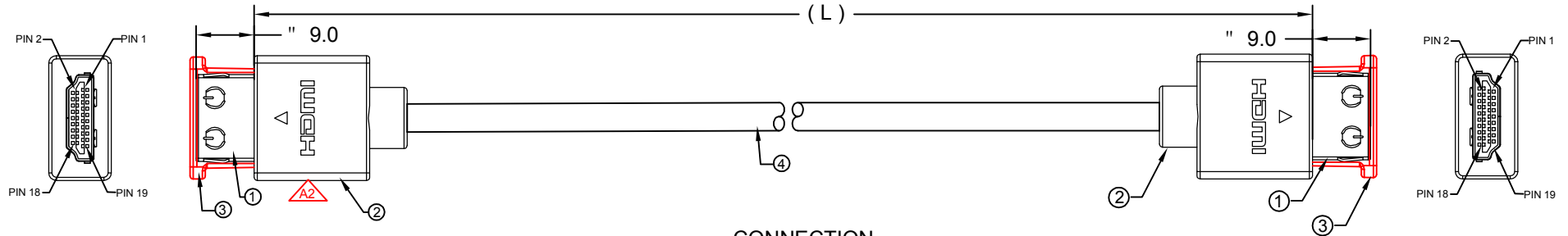

Packing: 1PC / Blister

**CONNECTION**

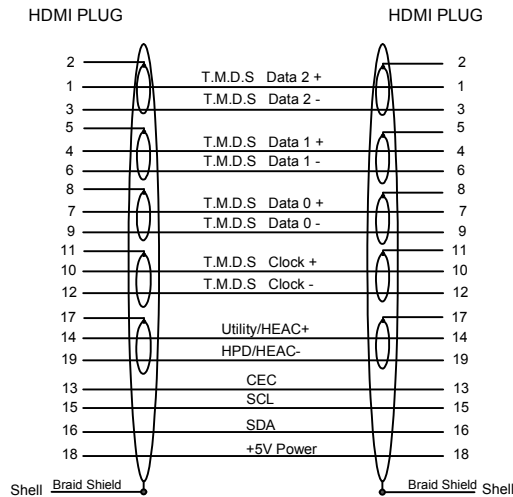

Sap No.	Part No.	Length (L)
	991UHD-0.5M	500 20mm
	991UHD-1M	1000 30mm
	991UHD-2M	2000 50mm

ELECTRIC TESTING:  
 1. 100% OPEN & SHORT TESTING  
 2. INSULATION RESISTANCE: 20 M  
 3. CONDUCTOR RESISTANCE: ! 3  
 4. VOLTAGE: 300V DC/0.1S

www.scpca5e.com

ITEM	SPECIFICATION
4	{{(1/0.16Bc+HDPE)*1P+1/0.16Tc+AL/Mylar}*5P+(1/0.16Bc+HDPE)*4C+Filler+AL Mylar+16/9/0.08(85%)Tc Braid}*1C OD=4.5 0.15MM Jacket=Black PVC Jacket with White Text :PREMIUM HIGH SPEED HDMI R(logo) CABLE WITH ETHERNET UL(Logo) AWM 20276 VW-1 80!C 30V E81280-D CHING TAI
3	Plastic Cap-Transparent(2312110024)
2	PVC - Black 60P (31401012060 YT-3497 / YT-3498)
1	HDMI Plug - Gold Plated (3033700A9G)

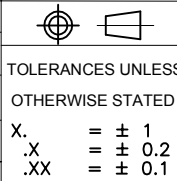

**Structured Cable Products™**  
Quality Installations Deserve Quality Products

ERP NO.:		Sample No.	
DOC No.:		REVISION	A2
CUSTOMER:		UNIT	mm
CUSTOMER P/N:		SCALE	NO
DESCRIPTION	Premium 2.0 HDMI A/P - HDMI A/P 34#	PAGE NO	1/1
		DATE	2016.06.22
APPROVAL	CHECKED	DRAWN	CJJ